

**Township of Parsippany – Troy Hills
Evaluation of Water Service Failures in the
Glenmont Commons Development**

Final Report January, 2015

1.0	Introduction	1.1
1.1	Study Background.....	1.1
1.2	Overview of Glenmont Commons Development	1.1
2.0	Identified Types of Water Service Line Failures	2.1
3.0	Potential Causes of Water Service Line Failures	3.1
3.1	Service Line Suitability for Application.....	3.2
3.2	Service Line Installation Procedures	3.2
3.3	Potential Manufacturing Defects	3.3
3.4	Township Operation of System	3.4
3.4.1	Water Delivery Pressure	3.4
3.4.2	Water Chemistry	3.7
4.0	Summary of Findings	4.1

Appendices:

- Appendix A: Failure Locations and Water Service Pressures
- Appendix B: Repair Locations and Activity
- Appendix C: Memo on #173 Springhill Drive Repair
- Appendix D: Endot Correspondence
- Appendix E: Plastics Pipe Institution, pages 27 – 34
- Appendix F: Community Affairs

1.0 Introduction

1.1 Study Background

The Township requested that Hatch Mott MacDonald (HMM) provide a third-party evaluation of water service line failures that have been occurring with increased frequency in the Glenmont Commons development. The study evaluates the types of water service failures experienced and the potential causes for the water service failures.

The water service piping that has experienced failures is 1-inch diameter polyethylene (PE) “Blue Jet Water Service Tubing” manufactured by Endot Industries, Inc.

1.2 Overview of Glenmont Commons Development

The Glenmont Commons and Glenmont Manor developments are served by a network of 8-inch through 12-inch diameter ductile iron pipe owned and operated by the Township. The water services from the water mains in the street to the curb stops are copper and are also owned by the Township. The polyethylene (PE) water services from the curb stop to the residences are owned by the residents.

Glenmont Commons and Glenmont Manor developments were granted permits to construct between August, 1998 and July 2004. The Glenmont Commons section includes 263 townhouses and 91 single-family homes and the Glenmont Manor section includes 46 single-family homes. The Township provided HMM with a list of 74 home owner (HO), water service failures that have occurred from June, 2011 through November, 2014. This represents 19 percent of the total services as failing in the Glenmont section of the Township with a much higher concentration of townhouse failures.

The operating and delivery pressure to customers in the development range from approximately 90 to 200 pounds per square inch (psi). Refer to the attached map in **Appendix A** that shows the general pressure to customers and identifies those properties where service failures have occurred.

2.0 Identified Types of Water Service Line Failures

Residents of the townhomes began experiencing failures of their water services that became apparent in several manners, including:

- Water entering basements from service line failures outside of the foundations;
- Service line failures within basements;
- Water surfacing outside of residences;
- Reduced pressures to residences; and
- Listening devices used by the Township on the service lines detecting noise attributed to service pipe leakage

Appendix B includes a listing of repair activity between May, 2011 and November, 2014. Although the repairs are noted over a span of almost four (4) years, this does not necessarily indicate that the services did not begin failing earlier. Many of the failing services were determined by the Township only after listening to the service lines (at the curb stops) for leaks. This was performed beginning in the summer of 2011 after the Township identified that a major source of unaccounted-for-water was within the Powdermill Manor gradient, the pressure zone which includes the Glenmont Commons development.

For the majority of the water service breaks, the service lines were replaced by the residents, and very little information was obtained as to the “type” of water service failure. Discussions with the Township indicated that the failures included small **longitudinal splits or punctures** to the pipe.

On September 6, 2013, the Township prepared an internal memorandum related to a service failure at 173 Springhill Drive (see **Appendix C**). This document indicates a “small puncture” and an indication that the potential cause was a rock impingement. The location of the failure was described as just outside the foundation wall of the residence, and differential settlement was also considered as potentially contributing to the failure.

Identified Types of Water Service Line Failures



173 Springhill Drive: Small puncture in pipe determined when pipe was pressure tested.¹



173 Springhill Drive: Pictures above show excavated material from line replacement.¹

¹ Township of Parsippany-Troy Hills, Water Department. Work Order Date: 9/6/13



30 Seasons Glen: Existing service installation with no controlled back fill and large rocks against the service line.²



124 Springhill Road: Existing service installation with no controlled back fill and large rocks against the service line.³

² Township of Parsippany-Troy Hills, Water Department. Notification Date: 12/19/14

³ Township of Parsippany-Troy Hills, Water Department. Work Order Date: 8/6/13

On May 15, 2014 and July 29, 2014 the Township received a sample of pipe from 46 Pinfold Court and 11 Summerhill Drive both with a longitudinal split.

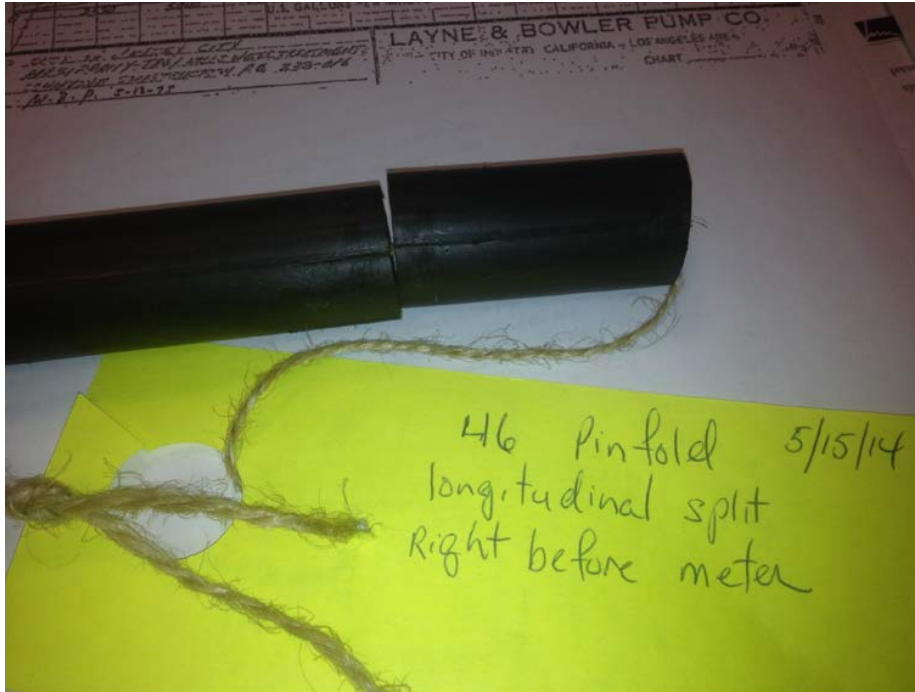

46 Pinfold Court: This pipe was cut in half after removal from inside wall of the residence. A longitudinal split can be seen on both sections of pipe. This sample was sent to Dr. Zhou, DOW Chemical for testing on July 22, 2014.⁴



11 Summerhill Drive.: A longitudinal split can be seen. Received on 7/29/14. Sent to Dr. Zhou, DOW Chemical for testing on September 19, 2014.⁵

⁴Township of Parsippany-Troy Hills, Water Department. Work Order Date: 5/15/14

⁵Township of Parsippany-Troy Hills, Building Department. Permit issued 7/25/14.

The Township also collected a sample of pipe from 17 Summerhill Dr. with a longitudinal split identified by Township personnel (no picture available of failed pipe; however, below are pictures of the trench that once housed it along with extracted backfill).⁶



⁶ Township of Parsippany-Troy Hills, Water Department. Work Order Dated: 5/17/13

3.0 Potential Causes of Service Line Failures

Section 2 described “puncture” and “longitudinal failures of the water service lines. HMM’s research identified that:

“PE pipeline networks have established an impressive safety record over the years, and are the preferred material of choice in the construction of gas and water distribution networks. However, failures can occur for an assortment of reasons including: system design, manufacturing practices, installation practices, accidental damage, incorrect material selection, thermal exposure, stressing beyond anticipated design stress, point loading and stress raisers, weathering, chemical exposure, and soil conditions.”⁷

For the majority of failures that have occurred, the Township has not been able to collect field information or field samples. For the majority of failures, the existing water services were abandoned in place, or otherwise damaged during the installation of the new water service. In many instances, new copper water services are being installed using a technique called “pipe bursting”. Using this technique, the new copper water service uses the old PE service line as a conduit for the new service. The PE pipe is burst open as the new copper is installed.

Of the 74 service line failures, there have been only four samples collected from the field:

- 173 Springhill Drive – puncture in pipe (water system pressure 140 to 160 psi)
- 17 Summerhill Drive – longitudinal split (water system pressure 160 to 180 psi)
- 46 Pinfold Court – longitudinal split (water system pressure 160 to 180 psi)
- 11 Summerhill Road – longitudinal split.

The following represents an evaluation of potential causes for the service line failures, including:

- Suitability of PE for Application
- PE Handling and Installation Procedures
- PE Manufacturing Procedures
- Water System Operation

⁷ Chris O’Connor, “The Nature of Polyethylene Pipe Failure, Pipeline & Gas Journal”, Dec. 2012, Vol 239, No. 12

3.1 Service Line Suitability for Application

Endot has indicated that their product has been used for water service installations throughout the United States. The 1996, 2000 and 2003 National Standard Plumbing Code Illustrated enforced by the NJ Department of Community Affairs (DCA) identifies PE pipe, similar to the manufacture of Endot's as suitable for water service installation. The Plumbing Code indicates that the PE service line material must be rated for a minimum of 160 psi.

It is noted that the PE service line pipe is rated for 200 psi working pressure. This is the pressure stamped on the pipe. The actual burst pressure of this pipe is much higher (samples tested by Endot burst at pressures above 500 psi as explained below).

It appears that this pipe was suitable for the application of water service in the development, where pressures range from 90 to nearly 200 psi. It is noted that failures have occurred as residences with pressures at the low range of 90 psi. The highest pressure associated with a water service failure appears to be approximately 180 psi.

3.2 Service Line Installation Procedures

There are many photographs taken of the excavations that show that the original water service lines were not bedded according to the manufacturer's installation procedures. The installation procedures indicate that the pipe should be embedded fully in soil material that is "free of rocks and debris". The pictures from the excavations, and the field reports from Township personnel indicates trenches with no select backfill, and large rocks installed directly against the water service piping. A proper installation would show the water service line encased in at least 6-inches of sand (or other select material) all around the water service.

The manufacturer's installation procedures indicate numerous times that service lines must be installed free of rocks and debris which could cause impingement on the water service and lead to failure.

In addition, there is some evidence of differential settlement of the ground at the foundation walls of the townhomes. This suggests that potentially the backfill material placed on the outside of the foundations was not properly compacted. Over time this settlement could have created stresses on the service lines and resulted in failures. The Township indicated that several failures appeared to have occurred very close to foundation walls where settlement had occurred.

3.3 Potential Manufacturing Defects

On November 7, 2013, Mr. Dick Kraft from Endot acquired two sections of exhumed water service line from the Township. These water service lines were sent to Dow Chemical Company (Dow), the supplier of the pipe, for analysis. Endot responded to the Township in a letter dated January 23, 2014 (copy in **Appendix D**), which included the following discussions:

- One sample of pipe (173 Springhill Drive) had a “ductile” failure when pressure tested to 850 psi and 900 psi. This is the normal anticipated failure mode for the pipe;
- One sample of pipe (17 Summerhill Drive) has a “non-ductile” failure when pressure tested to 550 psi and 600 psi. This failure is classified as “brittle” and is not the normal failure mode;
- Endot indicated that a test performed for depletion of anti-oxidant in the pipe, noted that the anti-oxidant package was somewhat depleted, but not enough to explain the brittle failure of the one piece of pipe;
- Endot requested additional information for the environmental factors associated with the pipe (i.e., water temperature, chlorine residual, internal pressure of the pipeline, pH of water)
- Endot indicated that additional testing will be performed by Dow on the pipe samples

Pipe sample from 11 Springhill Drive was forwarded to Dow for testing, concurrent as of the date of this paper.

Endot indicates that they will take responsibility for the cost of pipe repairs for the one sample (17 Summerhill Drive) if further testing by Dow determines the pipe or pipe resin was defective.

Endot indicates that they will only take responsibility for pipe where they can test a sample of pipe and confirm that the pipe or pipe resin is problematic. They are not indicating any responsibility for the other 49 water service failures brought to their attention at the beginning of the process.

At the current time, Dow has not provided the additional pipe analysis, and the pipe has been in Dow’s possession now for approximately four (4) months.

On May 15, 2014, the Township obtained another sample pipe from the residence at 46 Pinfold Court. This pipe shows a longitudinal split as well as the pipe sample obtained from 11 Summer Hill Road obtained on September 19, 2014. The location of the failure was inside the residence at 46 Pinfold Court and therefore, not associated

with any poor bedding installation outside and location of the failed pipe at 11 Spring Hill Drive was the underground service on the home owner's property leading to and underneath the porch.

3.4 Township Operation of System

An evaluation was performed to determine if the Township's operation of the water system may be contributing to the failures of the water services at Glenmont Commons. This includes a review of anticipated variations in the water delivery pressure, and also a review of the water chemistry.

3.4.1 Water Delivery Pressure

"In general practice, it is desirable to design water systems for delivery pressures to customer taps from between 40 and 100 psi."⁸ However, "In hilly regions pressures ranging from 100 – 130 psi or higher are not uncommon as a system supplies both high and low elevations."⁹ There are instances where hilly terrain makes it more economically viable to provide service at higher pressures than to attempt to divide a pressure zone into multiple, smaller gradients. When higher pressures are considered, it becomes a rather straightforward matter of providing an adequate design of water system piping and infrastructure to handle the higher pressures. The designs to handle higher water system pressures result in additional capital cost for materials of thicker/heavier construction that can handle the higher pressures. It is typical in these cases to install pressure reducing valves (PRVs) within the customer residences to reduce pressure so that the domestic plumbing isn't adversely impacted (e.g., washing machine hoses, etc.). The Glenmont Commons residences include PRVs in the basements.

In the Township, there are many areas of the water system that operate at pressures in excess of 100 psi. A review of the hydraulic model of the Township water system indicates that nearly 40 percent of the water system operates at pressures above 100 psi, 8 percent of the system operates at pressures above 125 psi, and 2 percent of the system operates at pressures above 150 psi (including customers outside of the Glenmont Commons development).

⁸ Hammer, Mark J. (1986). "Water and Wastewater Technology, 2nd Edition" John Wiley and Sons

⁹ LeChevallier, Yang, Xu, Hughes, and Kunkel, April 2014. "Pressure Management: Industry Practices and Monitoring Procedures" (Project #4321). Water Research Foundation, <http://www.waterrf.org/Pages/Projects.aspx?PID=4321>.

Customers that are served at high pressures (> 100 psi) outside of the Glenmont Commons do not have plastic services. The services found on the customer services are all copper. Compared to the 200 psi pressure rating of the plastic services found in the Glenmont Commons, copper services typically have a pressure ratings nearer to 400 psi.

However, the actual burst pressure of PE pipe is near 800 psi, therefore the system operating pressures are well within the actual pipe failure tolerances.

The Glenmont Commons development is part of the Township's Powdermill Manor gradient zone. Pressures within this zone range from approximately 75 to 200 psi. The pressure in the gradient zone is primarily controlled by the water elevation in the Powdermill Manor Tank. Based upon the hydraulic model, this tank has a normal operating range of between 1,100 and 1,120 feet above sea level. The elevation of the Glenmont Commons development ranges from approximately 700 to 900 feet above sea level. The pressure at any residence is the difference in elevation between the tank operating level and the elevation of the residence then divided by 2.31 to convert pressure from units of feet to psi.

The Powdermill Manor gradient zone is supplied water from either the Powdermill or Klondike Booster Station. The Powdermill Booster Station provides supply at 700 gallons per minute (gpm) and the Klondike Booster Station provides supply at 500 gpm. Based upon discussions with the Township, only one pump in one booster station is operated at a time.

The normal operation of a booster station includes a pump control valve. A pump control valve is used to reduce the potential for surges (transients) in the water system during pump startup.

Transients are abrupt changes in pressure caused by momentum changes in the liquid and related to how quickly velocity changes in the pipe system. Transients can result in momentary high pressures in the system that can damage pipelines.

When a pump starts, it starts against the closed valve. The valve then gradually opens to slowly introduce flow into the system. This results in a gradual change of velocity in the pipeline and no undesired transients. During pump shutdown, the valve gradually closes first, and then the pump is shut off.

A review of the hydraulic model, and supported by direct observation of Township personnel, indicate that the pressure in the system only increases by about 1 psi when a pump is in operation. This is primarily due to the 12-inch diameter pipelines on the discharge of the booster station that convey flow at low headloss.

Therefore, under normal operations, the pressure to the residences would only vary based upon the elevation in the storage tank. A 20-foot tank operating range results in approximately 9 psi of pressure at a residence. The pressures cited above for the Glenmont Commons are based upon a full tank.

The following items were evaluated as might relate to higher pressure occurrences in the Powdermill Manor gradient zone and Glenmont Commons development:

1. **Booster Station Pump Failure** – in the event there is a pump failure due to power loss or mechanical failure, the velocity in the pipeline can change abruptly and a transient pressure wave can result. The booster stations are outfitted with pressure relief valves in the event of a transient, but these alone cannot entirely prevent high pressures from occurring in the event of a pump failure. The Township has indicated that there have been limited pump/power failures in the system since the Glenmont Commons development has been constructed.
2. **Improper Fire Hydrant Operation** – If a fire hydrant is opened or closed too quickly it can result in transients occurring in the water system. Township personnel are all trained in proper fire hydrant operation, so transients caused by the Township are unlikely. However, landscapers often use hydrants to obtain water supply and the potential exists for improper hydrant operation. In the Township, landscapers are not allowed to open hydrants.
3. **Connection to Puddingstone Gradient** – The Puddingstone Gradient is adjacent to the Powdermill Gradient and is separated by a closed valve near the intersection of High Ridge Road and Violet Road. Since these gradient zones have basically the same hydraulic gradeline (tank operating ranges), it would be hard to tell if the valve between the zones was accidentally opened. Currently, the Puddingstone gradient zone is served by the Morris County Municipal Utilities Authority (MCMUA). In the event these two zones were interconnected, pumping from MCMUA could potentially result in transients.

Township personnel have indicated that the valve is currently closed and the system are indeed separated. A transient analysis has not been performed for the surge potential in the Powdermill Manor gradient zone at this time. It is not anticipated that the surge potential would exceed the 800 psi burst pressure of the service pipe. In summary, the operating pressures of the system, and any surge potential does not appear to be directly related to the failure of the water services.

3.4.2 Water Chemistry

Dow asked the Township to determine the following to evaluate if there are any environmental issues that may be causing or exacerbating the failures. The requested information and the Township response are below:

- 1) Average temperature of the water line in the area of failure – 56 degrees Fahrenheit
- 2) Residual chlorine levels at the Glenmont Commons area – 0.3 mg/l
- 3) pH of the water – 7.6

The supplied information does not indicate any potential problem with the water chemistry.

4.0 Summary of Findings

Beginning in 2011, the Township began receiving complaints from residents in the Glenmont Commons Development that they were experiencing failures with their 1-inch diameter polyethylene (PE) water services manufactured by Endot Industries, Inc. To date, 74 of the 400 water services in the aforementioned developments have required replacement due to failures (19 percent of water services reported).

Although most of the services have been replaced without identifying the types of service pipe failures, there is information on three (3) longitudinal pipe failures and one (1) puncture failure.

In general, the PE pipe manufactured by Endot is suitable for the application of water service. PE pipe is in the 1996, 2000 and 2003 National Standard Plumbing Code Illustrated enforced by DCA as an acceptable material. The water system operation does not appear to have any adverse impact on the pipe in service. The pressures of operation are within the 200 psi working pressure of the pipe, and the water chemistry does not appear to have any adverse impact.

Although the water system delivery pressures are high compared to the average water pressures typically found in water systems, they are not believed to be significant in relation to the observed water service failures. There have been failures of water services at 90 psi in Glenmont Commons, and this is a common operating pressure for water systems.

There is significant evidence of very poor installation procedures for the water service lines. The piping was not installed per the manufacturer's recommendations which call for the pipe to be installed in select backfill material (i.e., sand) that is free of debris and rocks. Appendix E: Plastics Pipe Institution, pages 27 – 34, outlines proper installation of PE water service lines. Additionally the 1996, 2000 and 2003 National Plumbing Code Illustrated also specifies proper installation procedures. There are many photographs and field observations of uncontrolled backfill material and rocks in direct contact with the pipe material.

In addition, there is some evidence of settlement that has occurred outside of the building foundations. This has been potentially caused by improper compaction of backfill. The settlement of trench material can add additional stress to the water service lines.

As stated in Title 5. Community Affairs, Chapter 23. Uniform Construction Code, Subchapter 2. Administration and Enforcement; Process, N.J.A.C. 5:23-2, specifically 5:23-2.2, the responsibility for work performed to code is the owner/contractor. Appendix F.

The Endot and Dow pipe testing, identified a “brittle” failure associated with one of the two pipe samples they were provided. This brittle failure may be related to a defect in the pipe resin (by Dow) or the manufacturing/extrusion process (by Endot). Dow is currently performing more tests on the pipe, and the results have not been provided at this time.

In summary, the pipe installation procedures were not performed in accordance with the manufacturer’s recommendations and this is seen as a primary potential reason for the number of water service failures. It will also be important to follow up with Dow to get the additional testing to see if there was a problem with the pipe resin or the manufactured pipe.

Since Endot has indicated they will pay for repairs for pipe that is shown to have a defect, it is recommended that more samples of pipe be obtained from failing services, as this might provide additional evidence of a potential pipe resin or pipe problem. These pipe samples should be exhumed with the least amount of damage possible, and must include the written information on the pipe that indicates that it is Endot’s pipe, and the information on when the pipe was manufactured. These samples could be sent to Dow for testing, or an independent laboratory (or both).

APPENDIX A

FAILURE LOCATIONS AND WATER SERVICE PRESSURES



Contours

Repair Location

Parcel Boundary

Aerial Imagery Date - April 3, 2012

0 100 Feet

Approximate Static Pressure (psi)	
■	< 100
■	101 - 120
■	121 - 140
■	141 - 160
■	161 - 180
■	181 - 202

TOWNSHIP OF PARSIPPANY-TROY HILLS
 MORRIS COUNTY, NEW JERSEY
 GLENMONT COMMONS STATIC PRESSURES

Hatch Mott MacDonald

Document Path: P:\328014\GIS\GlenmontCommonsRepairs.mxd
 Date Saved: 12/2/2014 8:24:03 AM

APPENDIX B

REPAIR LOCATIONS AND ACTIVITY

Glenmont Commons Repairs 2011/2012/2013/2014

Address	Service Ownership/Report Date	Corrective Action
136 Summerhill Dr.	Service on Township side of Curb stop	PTH Repair
117 Summerhill Dr.	Service on Township side of Curb stop	PTH Repair
64 Pinfold Ct.	Service HO (home owner) side	Leaking again 7.12.12
66 F Houston Taylor Ct	Service – HO Side	
196 Summerhill Dr..	Service ?????	
197 Summerhill Dr.	Service – HO Side	
297 Summerhill Dr..	Service – HO Side	
154 Springhill Dr.	Service – HO Side	
172 Springhill Dr.	Service - on Township side of Curb stop	PTH Repair
65 Springhill Dr	Service Both PTH side and Homeowners side	PTH Repair
23 Summerhill Dr.	Service – HO Side	
35/41 Summerhill Dr.	Replace Hydrant	developer replaced
83 Springhill Dr.	Service – HO Side	7/29/11
178 Summerhill Dr.	Service – HO Side 8/8/11	Claims to be BE REPAIRING 8/9/12
34 Pinfold Ct.	Service – HO Side	9/1/11
39 Pinfold Ct.	Service – HO Side 9/13/11	SKIP REPAIRING
61 Rookwood Terr.	Service - HO Side 6/25/11	done per CR
119 Summerhill Dr.	Service - HO Side 11/1/11	done per CR
142 Springhill Dr	Service - HO Side 11/1/11 Leaking 9/21/12	done 10/1/12
3 Gatheringhill Rd.	Service – HO Side 12/7/11	
5 F Houston Taylor Ct.	Service HO side – second occurrence – 12/14/11	Skip Repairing
239 Summerhill Dr.	Service – HO Side	4/13/12 done per CR
233 Summerhill Dr.	Service – HO Side	5/22/12 done per CR
26 Mill Run	Service – HO Side: 6/11/12	done per CR
4 Summerhill Dr.	Service – HO Side 7/9/12	back on 7/12/12 Repair?, 7/30/12
77 Summerhill Dr.	Service – HO Side	7/12/12 Fixed 2/7/13- Done
(Old Dover Road	Irrigation Pit - Pipe leak on ball valve	
40 Summerhill Dr.	Service – HO Side 7/20/12	Letter sent 7/25/12. Done per CR
160 Summerhill Dr.	Service – HO Side 7/26/12	Red Tagged 8/9/12. Done 9/14/12

Cont. Glenmont Commons Repairs 2011/2012/2013/2014

Address	Service Ownership/Report Date	Corrective Action
42 Rookwood	Service – HO Side	8/14/12 - done per CR
5 F Huston Talyor Ct.	Service – HO Side: 8/28/12	
298 Summerhill Rd.	Service – HO Side: 8/28/12	Confusion Confirm Leaking CR 9/20/12
82 Summerhill Dr.	Service – HO Side: 9/11/12	Done per KR, New Copper I
179 Springhill Dr.	Service – HO Side: 5/9/13	Done 2/6/13, local fix only
17 Summerhill Dr.	Service – HO Side: 5/9/13	Done 5/17/13 New copper. Split
59 Summerhill Dr.	Service – HO Side: 5/9/13	Leaking. Letter sent 8/23/13, Red Tag on 10/2/13. HO called 10/7to request extension.
167 Springhill Dr.	Service – HO Side 5/9/13	
178 Summerhill Dr.	Service – HO Side: 8/8/11	7/26/12, 1st Written Notice 9/13/12, Second written notice 10/15/12, 11/6/12 follow up, 2/11/13 follow up warning phone. Third letter issued on 4/25/13. No Response from HO. Red Card (Weeks' notice given) Shut Off on 5/13/13. HO calls on 5/13/13 and begs for water back on. Agreement is we will turn the water on provided he has made the repairs no later than June 1, 2013. 5/29/13 Homeowner hired contractor for a June 3 repair.
173 Springhill Dr.	Service – HO Side: 5/9/13	Leaking. Fixed: 8/16/13
61 Rookwood	Service – HO Side:	Fixed: 5/15/13
89 Springhill Dr.	Service – HO Side	Fixed: 6/18/13
29 Springhill Dr.	Service – HO Side	Fixed: 6/18/13
10 Summerhill Dr.	Service – HO side	Fixed: 7/15/13
5 Wiley Ct	Service HO side	Partial Repair: 8/2/13
124 Springhill Dr.	Service – HO side	Fixed: 8/6/13
17 Springhill Dr.	Service – HO side	Fixed: 8/16/13
125 Springhill Dr.	Service – HO side: 8/20/13	Leaking. Caused damage to #119 Springhill Repaired 8/27/13
172 Springhill Dr.	Service – HO side: 8/26/13	Leaking. Repaired 8/28/13
100 Springhill Dr.	Service – HO side: 8/26/13	Leaking. Repaired 8/30/13

Cont. Glenmont Commons Repairs 2011/2012/2013/2014

Address	Service Ownership/Report Date	Corrective Action
106 Springhill Dr.	Service – HO side: 9/10/13	Leaking, repaired 9/11/13
245 Summerhill Dr.	Service – HO side: 9/20/13	Leaking, repaired 9/21/13
71 Springhill Dr.	Service – HO side: 10/1/13	Leaking, repaired 10/2/13
142 Springhill Dr.	Service – HO side: 4/29/14	Re- Leaking, New Copper is leaking
149 Springhill Dr.	Service – HO side: 4/29/14	Leaking
46 Pinfold Ct.	Service – HO side: 5/15/14	Split indoors, flooded basement
39 Pinfold Ct.	Service – HO side: 5/29/14	Leaking, 2 nd time. Letter
16 Summerhill Dr.	Service – HO side: 6/2/14	Leaking, Replaced 6/6/14
5 F Houston taylor Ct.	Service – HO side: 7/18/14	Leaking, replaced 8/1/14
11 Summerhill Dr.	Service – HO side: 7/28/14	Leaking – Split in pipe exterior, replaced 8/1/14
269 Summerhill Dr.	Service – HO side: 8/5/14	Leaking –Replaced 8/15/14
33 Pinfold Ct.	Service – HO side: 8/14/14	Leaking –Replaced 8/15/14
5 Nutting	Service – HO side: 9/8/14	Leaking – Replaced 9/10/14
32 Rookwood	Service – HO side: 9/18/14	Leaking - Replaced
53 Springhill	Service – HO side: 9/29/14	Leaking – Replaced 9/30/14
58 Pinfold	Service – HO side: 10/5/14	Leaking
11 Seasons Glen Dr.	Service- Township Side: 10/8/14	Copper Leaking: Replaced 10/24/14
30 Seasons Glen Dr.	Service – HO side: 10/8/14	Leaking
142 Seasons Glen Dr.	Service – HO side: 10/8/14	Leaking
82 Summerhill Dr.	Service – HO side: 10/8/14	Leaking – Spot Repair Only
8 Millrun Ct.	Service – HO side: 10/31/14	Leaking – Replaced w/ Copper 11/10/14
94 Springhill Ct.	Service – HO side: 10/31/14	Leaking
179 Springhill Ct.	Service – HO side: 10/31/14	Leaking
10 Summerhill Dr.	Inside dwelling: 10/31/14	Leaking toilet
34 Summerhill Dr.	Service – HO side: 10/31/14	Leaking toilet
172 Summerhill Dr.	Service – HO side	10/31/14 Leaking – No Leak, Retracted Letter
9 Gathering Hill Court	Service – HO side: 11/26/14	Fixed: 12/6/14
11 Seasons Glenn	Service - HO	Fixed 12/4/14
30 Seasons Glenn	Service - HO	Fixed 12/19/14

APPENDIX C

MEMO ON #173 SPRINGHILL DRIVE REPAIR

TOWNSHIP OF PARSIPPANY-TROY HILLS

Memorandum

To: Paula Cozzarelli
Director of Municipal Utilities

From: John Wieworka
Assistant Water Superintendent

Date: September 6, 2013

Re: #173 Springhill Dr
Glenmont Commons
Replacement of Water Service

On Friday September 6, 2013 the Parsippany Water Dept observed the replacement of the water service leading to #173 Springhill Dr. The owner of the property hired Red, White & Blue Excavating out of Jefferson (862-432-8319) to do the excavation, and Bianco Diamond Plumbing out of Flanders (973-584-8415) to do the plumbing work.

During our observation it was noted that rocks of varying size where being removed from the excavation. These rocks were also present in the embedment zone of the pipe. The rocky fill was present throughout the excavation. We did not observe any select backfill on the private property. Just the mix of rocky fill that is native to the mountain.

The area of the leak was located 12 inches from the foundation. This area had significant settlement prior to the start of work. At no time did the leak make its way to the surface. It was noted that rocks where directly on top of the pipe at the point of failure. The pipe also was severely deflected either from settlement or from the backfill process at the point of failure. The failure was a small puncture created by the rock which was in contact with it. The Water Department has this section in their possession.

The new ¾ inch copper service was installed and bedded in clean sand backfill. Several photographs were taken throughout the process.

APPENDIX D
ENDOT CORRESPONDENCE



**ENDOT
INDUSTRIES, INC.**

Corporate Headquarters

60 Green Pond Road
Rockaway, NJ 07866
Tel 973-625-8500
Fax 973-625-4087

Tennessee Operation

400 Bohannon Avenue
Greeneville, TN 37745
Tel 423-639-8241
Fax 423-639-3722

Oklahoma Operation

2615 OK Hwy 69A
MidAmerica Industrial Park
Pryor Creek, OK 74361
Tel 800-44ENDOT
Fax 973-625-4087

PIPE & TUBING
DUCT & INNERDUCT

January 23, 2014

Township of Parsippany-Troy Hills
1001 Parsippany Boulevard
Parsippany-Troy Hills, NJ 07054
Attention: Paula Cozzarelli

Dear Ms. Cozzarelli:

Endot has received the report from Dow regarding the HDPE resin taken from the pipe samples your water department provided to Endot. The testing was performed to determine if the resin was from Dow and to what extent the Anti-oxidant package (AO) in the HDPE resin has been depleted. At this time the report is indicating that the resin is from Dow and the AO in the HDPE resin has been somewhat depleted. The amount of depletion found is not significant relative to the ability of the pipe to withstand oxidation. Anti-oxidants are used to provide protection against attack by disinfectants such as chlorine and chemicals that might be found in the environment. The level of AO depletion seen does not explain the failure or the results of burst testing done by Endot..

AO depletion caused by environmental issues can be the result of high concentrations of chlorine left in the pipe for extended periods of time such as when pipe is disinfected prior to being put into service. It can also be the result of chemical contamination in the ground where the pipe is installed. Chlorine normally found in potable water will not on its own cause significant depletion of the AO. When a combination of factors such as high pressure, consistent elevated temperatures, aggressive water conditions (pH) are present with the chlorine the pipe resin's AO can be depleted leading to premature failures. These conditions do not all have to exist together, but a combination of two or three can be a lead to rapid AO depletion.

We asked Dow to explain more fully their findings relative to the failures seen and if they need any additional information on the environment the pipe is operating in to reach a conclusion or to determine what if any additional testing is needed.

Dow has asked us to determine the following to evaluate if there are any environmental issues that may be causing or exacerbating the failures;

- 1) Average temperature of the water line in the area of failure
- 2) Average internal pressure of the water line
- 3) Residual chlorine levels at the Glenmont Commons area
- 4) pH of the water

Dow also asked us what type and size of fill was used in the installation of the pipe as well as any conditions about the installation such as depth of burial, are any of the services under streets or driveways etc. that can be determined. Earl Schneider of Hatch Mott McDonald indicated that many of the failures were near the foundations and it would be helpful to know if this is true and any other information about the location of the failures that is available.

Pipe Samples from Glenmont Commons:

Data Provided by Dick Kraft

- 1) Print Line from Pipe Sample #1 (173 Springhill);

1" WST 200 PSI SDR 9 73.4°F ENDOT ENDOPOLY WATER SERVICE TUBING
ASTM D2737 PE 3408 NSF pw LOT C-3 EIC-80 R P1 SEP 06 01 SHIFT L.C.

Pipe sample # 1 demonstrated a ductile burst at 850 psi and 900 psi in two tests Endot performed.

Based on comments by John Wieworka of the Parsippany Water Dept. and Endot's observation this pipe had holes in it that were caused by rocks on the pipe and not a result of defective pipe material.

- 2) Print Line from Pipe Sample #2 (17 Summer Hill);

1" WST 200 PSI SDR 9 73.4°F ENDOT BLUE JET WATER SERVICE TUBING
ASTM D2737 PE 3408 NSF pw LOT C-3 EIC-80 R P1 NOV 13 99 SHIFT A.R.

Pipe sample # 2 demonstrated a non-ductile burst at 550 psi and 600 psi in two tests Endot performed.



**ENDOT
INDUSTRIES, INC.**

Corporate Headquarters

60 Green Pond Road
Rockaway, NJ 07866
Tel 973-625-8500
Fax 973-625-4087

Tennessee Operation

400 Bohannon Avenue
Greeneville, TN 37745
Tel 423-639-8241
Fax 423-639-3722

Oklahoma Operation

2615 OK Hwy 69A
MidAmerica Industrial Park
Pryor Creek, OK 74361
Tel 800-44ENDOT
Fax 973-625-4087

PIPE & TUBING
DUCT & INNERDUCT

January 23, 2014

Attention: Paula Cozzarelli

In addition Endot is sending more pipe from the pieces supplied to Endot by your Water Department to Dow for additional testing based on the findings so far.

Endot does warranty their pipe, a copy of the warranty is attached to this correspondence. In the warranty it is indicated the installer is to fill out a short installation record form and send it to Endot. If this had been done at Glenmont Commons Endot would know what service lines in Glenmont Commons were installed using Endot pipe and been able to address the question you have asked about the other units and what could be done going forward about them. With no record of installations and no knowledge of who the installation contractors were or where they purchased the pipe there is no way to determine how many if any of the units have Endot pipe installed. There are many producers of HDPE pipe and distributors often carry more than one brand or change brands over the years. It is very possible that the service lines in other units at Glenmont Commons were installed using brands other than Endot.

Of the 45 failures you have indicated occurred Endot has been given two samples of failed pipe. We asked for samples when initially contacted, but were told none were available. The samples given to Endot for testing are from two different production runs, two years apart. These samples are the ones sent to Dow for analysis. Endot's own testing shows one of the samples to have failed due to a rock impingement and not material failure. The other appears to be a material failure, but the level of AO depletion alone does not explain this. As a result Dow will have to perform additional testing to determine the cause of failure. If it is confirmed that this one failure is a result of defective pipe or pipe resin Endot will accept responsibility and address the cost of repairs for this one service as well as provide new pipe to do the repairs.

Going forward should additional service lines fail Endot will need samples of the pipe with complete print lines indicating the manufacture and lot and date codes. If the pipe is Endot's and we determine the failure to be a result of defective pipe or pipe resin and not environmental issues such as improper installation Endot will accept responsibility and address the cost of repairs as well as provide new pipe to do those repairs.

I am available if you wish to discuss this matter further or have additional questions.

Yours truly,

Richard G. Kraft
VP Sales Marketing

cc: Jennifer Marin, President

Progress Test report On ENDOT Pipe Samples

Subject Samples

Two 1" SDR black pipe samples were received from ENDOT with about 3.5" long.

Sample ID 781374 - 1" pipe with printline of Nov 1999

Sample ID 781375 – 1" pipe with red tape

Objective

To determine what resin was used for making the pipe and properties of the piping resin.

Technical Approach

1. ICP Element Analysis
To measure the content of AOM tracer to see if Dow tracer is inside the pipe
2. Thermal stability
To measure the anti-oxidation additive level inside the pipe.
3. DMS at 190C
To measure the viscosity as a function of shear rate to get melt behavior

Test results

1. AOM Tracer measured by ICP

The test results are listed in the following table.

Element	Mo	AOM
Reporting Limit	< 1 ppm	ppm
Sample ID		
781374	52.7	86.2
781375	43.3	70.8

AOM tracer was detected inside the pipe material. The concentrations were in the specification of Dow pressure pipe resin formulation. It indicated that the pipe could be extruded from Dow pressure pipe resin formulation that is listed by PPI TR-4 and NSF Standard 14 and 61.

Around 1999, Dow sold DGDB-2480 high density PE3408 pressure pipe resin to the market place. Most likely the two pipe samples were made from Dow DGDB-2480 resin. DGDB-2480 was classified as PE3408 in accordance to ASTM and PPI standards before 2005. Currently DGDB-2480 resin is classified as PE3608 in accordance to current ASTM standard. Dow Chemical has offered DGDB-2480 to the pipe industry for more than 30 years.

2. Thermal Stability

The following DSC charts measured the thermal stability in OIT (Oxidation Induction Time). They are in the low end of the specification but still meet the product and standard requirement. The two samples essentially had the same level of AO package.

It is common to have relative low AO concentration in service pipe due to the slow leaching out of AO additives by water transportation. Pipe extrusion might decrease the AO concentration but it would take 7 to 8 extrusion cycles to see a significant decrease.

Sample: 781374 black pipe Nov 1999
Size: 3.2980 mg
Method: Thermal Stability Temp Ramp
Comment: Leal-Zhou

DSC

File: C:\TA\Data\DSC\781374.003

Run Date: 16-Dec-2013 10:45

Instrument: DSC Q2000 V24.10 Build 122

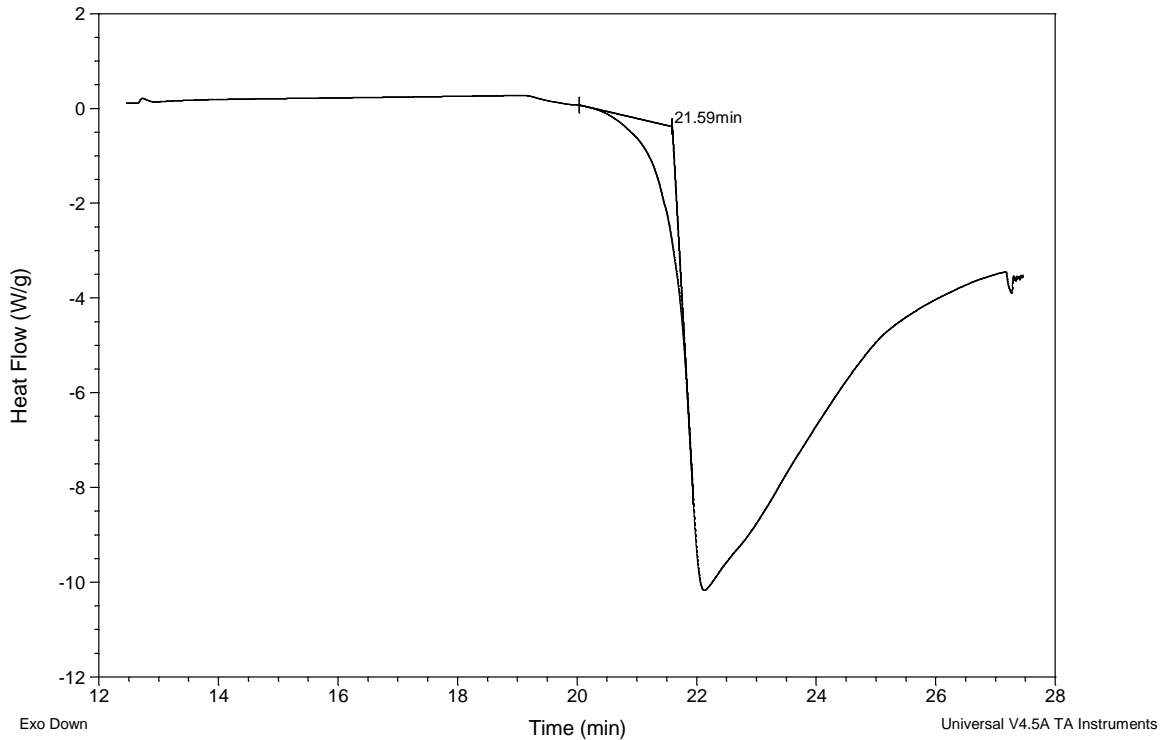

Sample: 781375 black pipe with red tape
Size: 6.0890 mg
Method: Thermal Stability Temp Ramp
Comment: Leal-Zhou

DSC

File: C:\TA\Data\DSC\781375.002
Run Date: 18-Dec-2013 03:10
Instrument: DSC Q2000 V24.10 Build 122

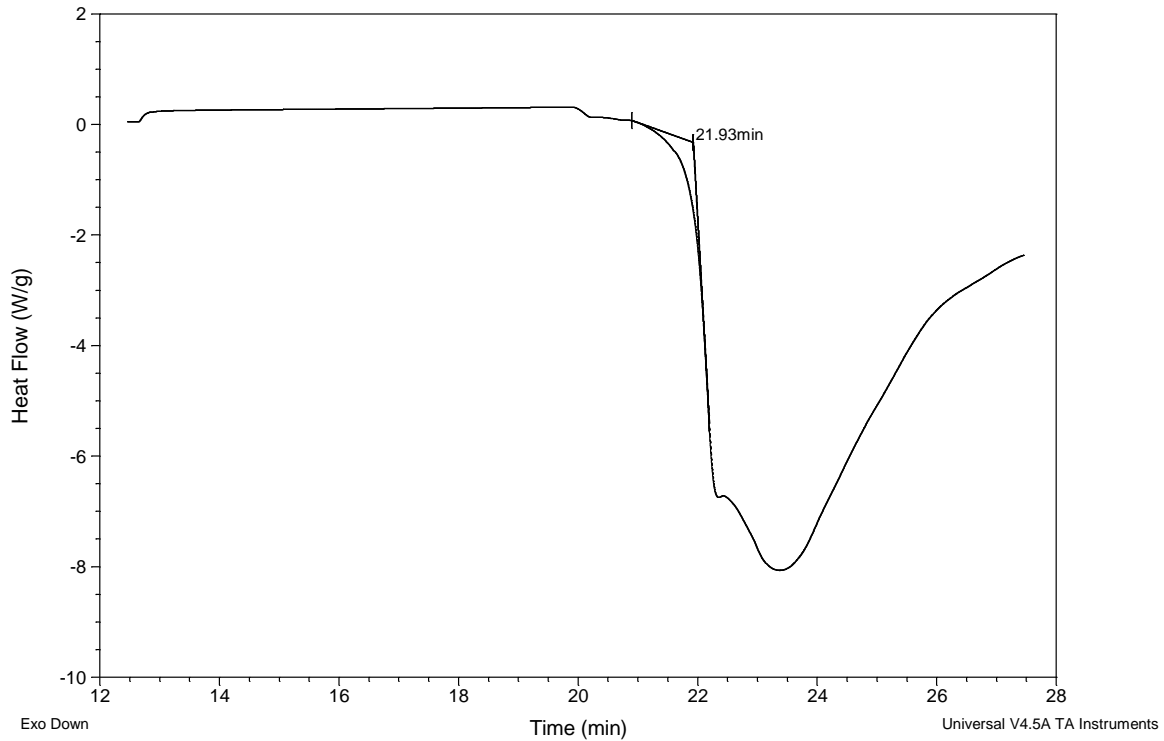

3. DMS data

The following charts are the viscosity versus shear rates of the two samples at 190C. Since most likely DGDB-2480 resin was used to make the pipe samples, DMS chart measured from virgin DGDB-2480 resin was taken as a reference to compare with that measured on the two field pipe samples. 781374, the 1" black pipe with printline of November 1999 is identical to that of the virgin DGDB-2480. 781375, the 1" black pipe with red tape is almost completely overlapped with the exception of the lower viscosity curve at the low shear rates.

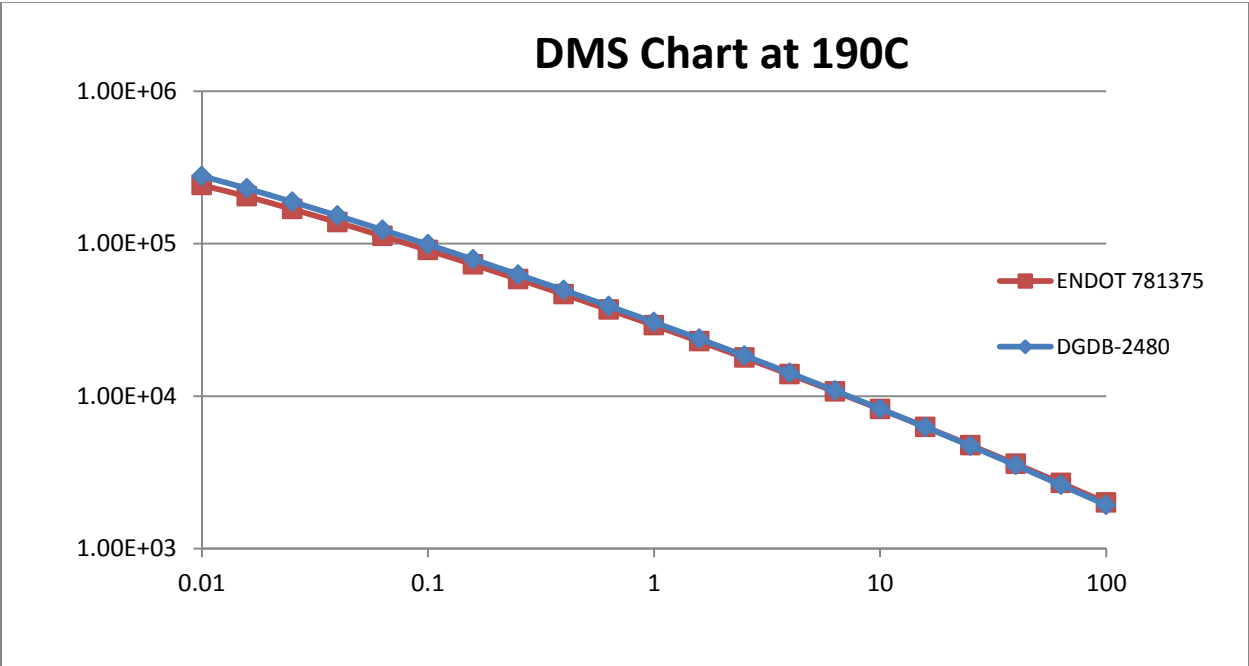
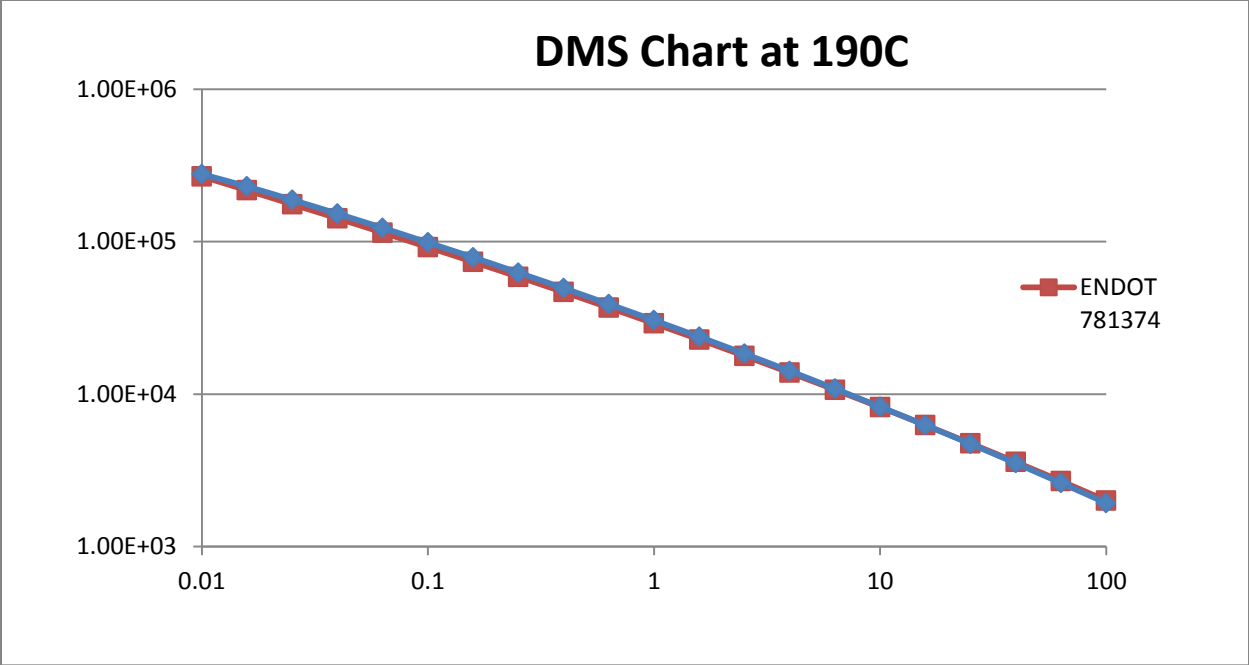

Discussion

Dow AOM tracer was found inside the two black pipes, indicating that the two pipe samples could be extruded from Dow pipe resin. Based on the pipe printline of 1999, most likely DGDB-2480 was used to

make the pipe. DGDB-2480 was a PE3408 pressure pipe resin in accordance to ASTM standard before 2005 and a PE3608 pipe grade in accordance to ASTM standard after 2005.

Thermal stability as measured by OIT (Oxidation Reduction Time) was in the low end of the specification but still meet resin product specification. The two samples essentially had the same thermal stability.

DMS measures the viscosity as a function of shear rate at various temperatures. At a given shear rate and temperature, the viscosity is controlled by molecular weight and distribution, long chain branching, and crosslinking. If the molecular degradation happens, the chain scission and crosslinking might occur. As a result, the viscosity curve could be different.

Sample 781374 seems to be identical to virgin DGDB-2480. No degradation was indicated. Samples 781375 displayed slightly lower viscosity at low shear rates. The viscosities at low shear rates are the responses of the high molecular weight part of the resin.

Based on the limited preliminary data, it is difficult to draw any conclusions. It is suggested to do further testing. In order to eliminating the sampling issue, it is further suggested to have the real failed pipe samples from the field. Testing directly on the failed samples will have better correlations between tested properties and the real field performance.

APPENDIX E
PLASTICS PIPE INSTITUTION
(Pages 27–34)

PE Water Distribution Piping

Sizes, Pressures, and Specifications

PE water distribution lines are typically 4" to 12" nominal diameter pipe in accordance with AWWA C906, ASTM D3035, or ASTM F714, with rated pressure of 80 to 250 psig in accordance with Table 1.

Burial

The materials enveloping a buried pipe are generally identified as shown by their function or location (see Figure 20).

Figure 20 Pipe Trench

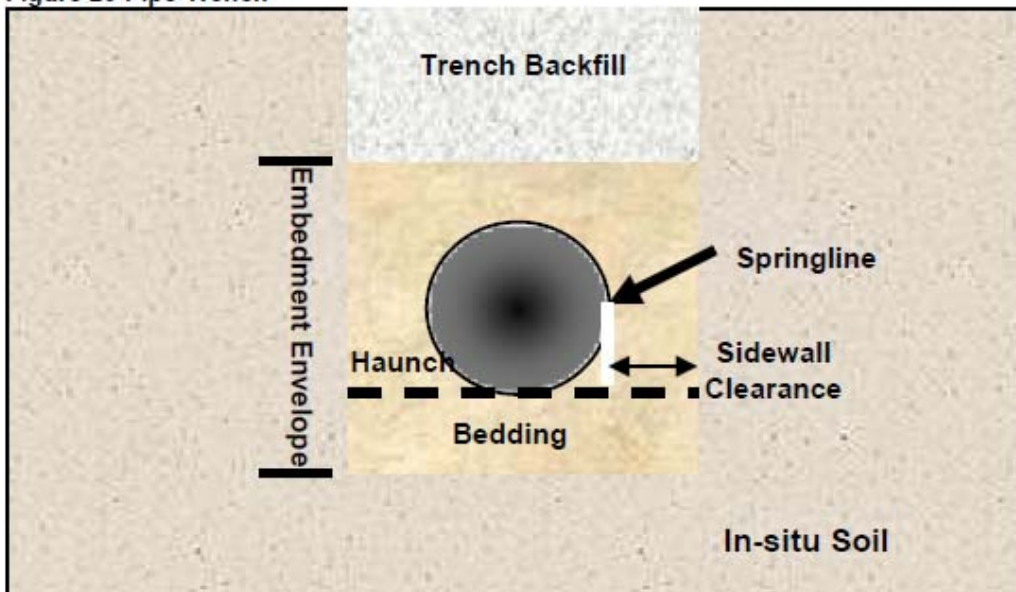

Installation Guidelines for PE Pipe

Install PE pressure pipe in accordance with ASTM D2774.

The engineer must evaluate the site conditions, the subsurface conditions, and the application objectives to determine the extent of support the pipe may need from the surrounding soil. Where the pipe burial depth is relatively deep, where subsurface soil conditions are not supportive of pipe, where surface loads or live loads are present, or where the pipe DR is high, the engineer will generally prepare a specific installation specification. The specific engineered installation instructions should be followed.

The following are general guidelines for the installation of 12" and smaller diameter PE pipe with a minimum cover depth of 2 ft (3 ft under traffic loading; up to 5 feet for frost protection) and a maximum depth of cover of 16 feet. For other depths consult the engineer. Other satisfactory methods or specifications may be available. This information should not be substituted for the judgment of a professional engineer in achieving specific requirements.

Figure 21: Pipe Placement in Open Trench



Trench Construction

Principal considerations in trench construction are trench width, length, and depth; soil stability; and groundwater accumulation in the trench. Unstable soils or wet conditions should be controlled by sloping or bracing the trench walls, de-watering the trench bottom, and/or other measures.

Trench Width

The trench width should allow sufficient room for joining the pipe, if required, snaking small diameter from side to side along the bottom of trench for thermal affects, and filling and compacting the side fills. Table 3 gives suggested minimum trench width values.

TABLE 3
Minimum Trench Width in Stable Ground vs. Pipe Size

Nominal Pipe Size (in.)	Minimum Trench Width (in.)
<3	12
3-12	Pipe OD + 12

Trench Length

The length of open trench required for fused pipe sections should be such that bending and lowering the pipe into the ditch does not exceed the manufacturer's minimum recommended bend radius and result in kinking. Table 4 lists the recommended lengths of trench openings for placement of continuous lengths of fused pipe, assembled above the trench. When the trench sidewalls are significantly sloped, somewhat shorter trench openings may be used.

TABLE 4: Suggested Length of Minimum Trench Opening (Feet) for Installation of Joined Lengths of PE Pipe

Nominal Pipe Size (inches)	Depth of Trench (feet)					
	3	5	7	9	11	13
½ to 3	15	20	25	30	35	40
4 to 8	25	30	35	40	45	50
10 to 12	35	40	45	50	55	60

Stability of Trench Walls

The embedment material must be placed from undisturbed trench sidewall to undisturbed trench sidewall. Walls of trenches below the elevation of the crown of the pipe should be maintained as vertical as possible. Sloping of trench walls in granular and cohesionless soils should be provided whenever the walls are more than about four feet in depth or otherwise required by state, local or federal regulations. For safety, if the walls are not sloped, they should be stabilized by shoring or bracing. The slope should be approved by the engineer.

Stable soils can be cut vertically or nearly vertically without significant sloughing. If trench sidewalls readily slough off or the trench floor is soft and will not support workers or compaction, it is unstable. The instability is usually a condition of the trench and not the soil. Most often the cause is high groundwater. In unstable soils, the engineer should determine the necessity for special procedures such as a "wide" trench or permanent trench sheeting.

Wherever possible, temporary sheathing and bracing to protect workers should be installed so that its bottom extends no lower than about one-quarter of the pipe diameter below the pipe crown. Sheathing that is installed to project below the pipe springline should be left in place unless, as with some thinner sheathing, it is designed to be pulled and removed without disturbing the embedment next to the pipe. In this case, the trench width should be increased by 12 to 24 inches, depending on the pipe diameter, to allow for minor disturbance to the embedment near the sheathing. Do not use vibratory placement or extraction of sheeting. This can cause severe disturbance to the bedding and liquefaction of the surrounding soils.

Portable Trench Shield

Portable trench shields or boxes can be used with PE pipe. All excavation of the trench below the pipe crown elevation should be done from inside of the shield. The backhoe operator should dig inside of the shield and force the shield down as soil is removed. Where the bottom of the shield extends below the pipe crown, the shield must be vertically raised after each lift is placed and embedment material shovelled under the shield to fill the void created by the shield wall. Figure 22 illustrates the steps used with a Portable Trench Shield.

If possible, use shields that are placed with no portion of their sides extending lower than one-quarter of a pipe diameter below the pipe crown. This minimizes the amount of lifting required and precludes the possibility for disturbing embedment materials. The minimum inside clear width of the box or shield should allow for the minimum trench width requirements for the pipe plus an additional 12 to 24 inches

Figure 22: Installing PE Pipe with a Portable Trench Shield

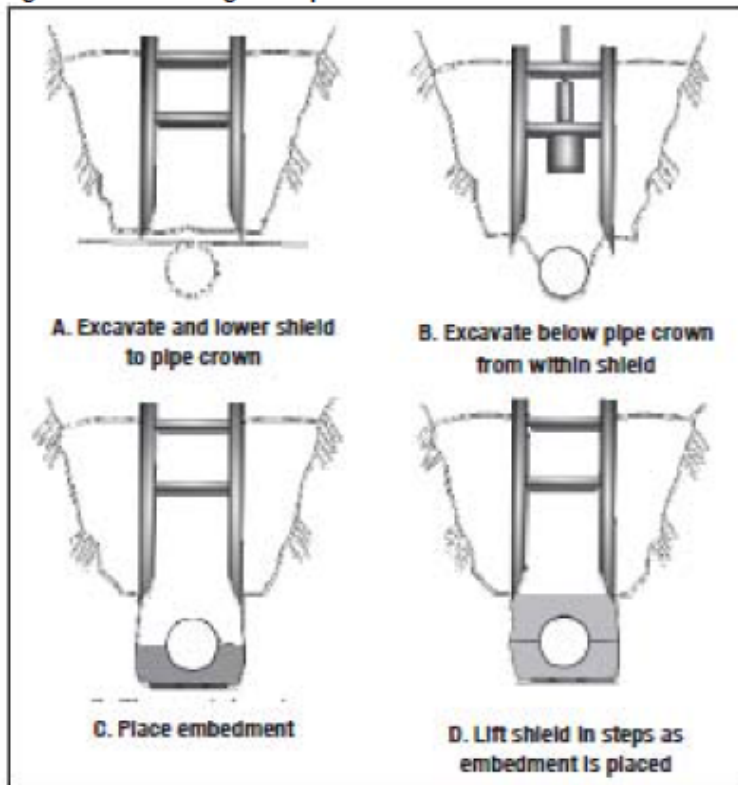

Trench Floor Preparation

The trench floor must be stable in order to support the bedding material. Generally, if the trench floor can be walked on without showing foot prints it is considered stable. Where the trench floor is not stable, in many cases it can be stabilized by dewatering. Where dewatering is not possible stabilization of the trench floor may be accomplished by addition of crushed rock or by an alternate trench foundation.

Pressure pipe may be installed directly on the prepared trench floor as long as it is soil. The trench bottom may undulate but must support the pipe smoothly and be free of ridges, hollows, and lumps. The trench bottom should be relatively smooth and free of rock. Rocks, boulders, or large stones that can cause point loading on the pipe must be removed and the trench bottom padded with 4 to 6 inches of tamped bedding material. Bedding should consist of free-flowing material such as gravel, sand, silty sand, or clayey sand that is free of stones or hard particles larger than specified for the embedment size.

If you over-excavate the trench floor by more than 6 inches beyond grade, fill the over-excavation with acceptable material that is compacted to a density equal to that of the embedment material.

De-watering

The groundwater in the trench should be kept below the pipe invert, using deep wells, well points or sump pumps placed in the trench.

Placing Pipe in Trench

Place PE pressure pipe up to 8" in diameter in the trench by hand. Use equipment to lift, move, and lower larger diameter pipe into the trench. Pipe must not be dumped, dropped, pushed, or rolled into the trench.

Figure 23: Trench Wall Sloped for Safety



Pipe Embedment

ASTM D2774 calls for embedment materials to be sufficiently granular for haunching under the pipe and compacting. Typical soils include coarse grained soil, such as gravel or sand, or coarse grained soil containing fines, such as silty sand or clayey sand. Compactable native soil is acceptable where there is no traffic load. This includes lean clays and silty sand. The particle size should not exceed the values in Table 5.

Where the embedment is angular, crushed stone may be placed around the pipe by dumping and slicing with a shovel. Where the embedment is naturally occurring gravels, sands and mixtures with fines, the embedment should be placed in lifts not exceeding 8 inches in thickness and then tamped. Tamping should be accomplished by using a mechanical tamper. Compact to at least 85 percent Standard Proctor density as defined in ASTM D698, *Standard Test Methods for Laboratory Compaction Characteristics of Soil Using Standard Effort*, (12 400 ft-lbf/ft³ (600 kN-m/m³)). Under streets and roads, increase compaction to at least 95 percent Standard Proctor density.

Table 5: Embedment Size vs. Diameter of Pipe

Pipe Diameter	Particle Size
≤4"	≤1/2"
6" & 8"	≤3/4"
10" to 16"	≤1"
≥18"	≤1-1/2"

Figure 24: Typical granular embedment



Backfilling and Compaction

Backfilling should follow pipe placement and assembly as closely as possible to prevent the pipe from being shifted out of line by cave-ins, protect the pipe from external damage, eliminate pipe lifting due to flooding of open trench and lessen the possibility of backfill material becoming frozen in cold weather.

Where the in-situ soil is fine grain, backfill material should be selected to prevent material migration to or from the trench wall and other layers of embedment material.

Backfill under the pipe haunches to at least 6 inches above the pipe with the select embedment soil. Shovel slice or compact in lifts not exceeding 8" as required. Place lifts evenly on both sides of the pipe. Rock impingement may cause high contact stresses and stress raisers in pipe wall. Keep large hard objects away from the pipe. See Figure 25.

If the final backfill material contains large rock (boulder or cobble size) or clumps, then 18 inches of cushion material should be provided between the pipe crown and the trench backfill.

The final backfill may consist of the excavated material, provided it is free from unsuitable matter such as large lumps of clay, organic material, boulders or stones larger than 8 inches, or construction debris. The final backfill may be placed in the trench by machines.

There should be at least one foot of cover over the pipe before compaction of the final backfill by the use of self-powered compactors. Construction vehicles should not be driven over the pipe until a three foot cover of properly compacted material is placed over the pipe.

Where the pipe is located beneath a road, place the final backfill in lifts and compact to 95 percent Standard Proctor Density.

Fig. 25: Avoid Rock Impingement when Placing Embedment



Sunlight Exposure During Installation

Placing pipe that has been in direct sunlight in a cooler trench will result in thermal contraction of the pipe's length. This contraction can generate force which could result in pull-out at mechanical couplings or other buried structures. Allow pipe to cool before making connections to an anchored joint, flange, or a fitting that requires protection against excessive pull-out forces. Covering the pipe with embedment will facilitate cooling.

Deflection

Small diameter pressure pipes usually have adequate stiffness and are usually installed in such shallow depths that it is unnecessary to make an internal inspection of the pipe for deflection.

APPENDIX F
COMMUNITY AFFAIRS

(b) Professional architecture or engineering services:

1. Design: All new, renovation, alteration, reconstruction, expansion, addition or modification work involving the practice of professional architecture or engineering, as defined by the statutory requirements of the professional registration and licensing laws of this State, shall be prepared by registered architects or licensed engineers. All plans, computations and specifications required for a construction permit application must be prepared by or under the direct supervision of a registered architect or licensed engineer and bear his or her signature and seal in accordance with the State's statutes and regulations governing the professional registration and licensing of architects and engineers.

(c) Responsible person in charge of work: The owner shall designate a person to be in charge of the work who shall be responsible for:

1. Verification of all controlled materials per building subcode requirements of testing, certification and identification;
2. Special inspection of critical construction components;
3. Submission of amended plans and specifications whenever substantial deviations are necessary or desired, or when required to do so pursuant to N.J.A.C. 5:23-2.15(f)4v; and
4. The responsible person in charge of work shall perform the necessary services and be present on the construction site on a regular and periodic basis to determine that, generally, the work is proceeding in accordance with the code and any conditions of the construction permit.

(d) Reporting: At the completion of the construction, the responsible person in charge of work shall submit to the construction official a report as to the satisfactory completion and the readiness of the project for occupancy and shall certify that, to the best of the responsible person's knowledge and belief, such has been done substantially in accordance with the code and with those portions of the plans and specifications controlled by the code, with any substantial deviations noted.

(e) Construction contractor services: The actual construction of the work shall be the responsibility of the contractor(s) as identified on the approved construction permit and shall involve:

1. Execution of work in accordance with the regulations;
2. Execution and control of all methods of construction in a safe and satisfactory manner;
3. Execution of all work in accordance with the code and those portions of the plans and specifications controlled by the code;

4. In general, render all such construction services as required to effect a safe and satisfactory installation of the project;

5. Upon completion of the construction, the contractor shall certify to the best of the contractor's knowledge and belief that such has been done substantially in accordance with the code and with those portions of the plans and specifications controlled by the code, with any substantial deviation specifically noted.

(f) The provisions of this section do not relieve the enforcing agency of any of the responsibilities required by the regulations.

Amended by R.1998 d.28, effective January 5, 1998.
See: 29 N.J.R. 3603(a), 30 N.J.R. 129(a).
Amended by R.2003 d.216, effective May 19, 2003.
See: 35 N.J.R. 16(a), 35 N.J.R. 2203(a).
Rewrote the section.
Administrative correction.
See: 39 N.J.R. 4571(a).

Case Notes

Initial Decision (2006 N.J. AGEN LEXIS 428) adopted, which found that while the photographs and testimony indicated that 105 Mary Street had some structural supports, the lack of evidence that each and every element that required structural support had been adequately braced or shored forced a conclusion that the N.J.A.C. 5:23-2.21(e)(4) requirement to effect a wholly safe installation had not been met. Office of Local Code Enforcement, Dep't of Community Affairs v. Brassel, OAL Dkt. No. CAF 02684-06, 2006 N.J. AGEN LEXIS 512, Final Decision (June 16, 2006).

5:23-2.22 Premanufactured construction

(a) Premanufactured construction certified in accordance with N.J.A.C. 5:23-4A through 4D, as applicable, and carrying an appropriate label, shall be accepted as conforming to the requirements of the regulations to the extent provided for by the particular label for purposes of local construction inspection approval.

1. Prior to accepting the unit, the appropriate subcode official may require the performance of nondestructive tests.
2. In the case of visible signs of damage and/or any visible code violations, the construction official shall consider the seriousness of the nonconformance or damage and accordingly issue a Temporary Certificate of Occupancy or Certificate of Occupancy or deny such Certificate. If a Temporary Certificate is issued or a Certificate is denied, the construction official shall request that the label-issuing agency reaffirm in writing that the assembly still conforms to the regulations and notify the Department in writing.
3. No inspection requiring disassembly, damage to, or destruction of certified premanufactured construction shall be conducted.

(b) The appropriate subcode officials shall inspect the installation of any premanufactured unit or assembly and all